

MODEL: MC2.3-12

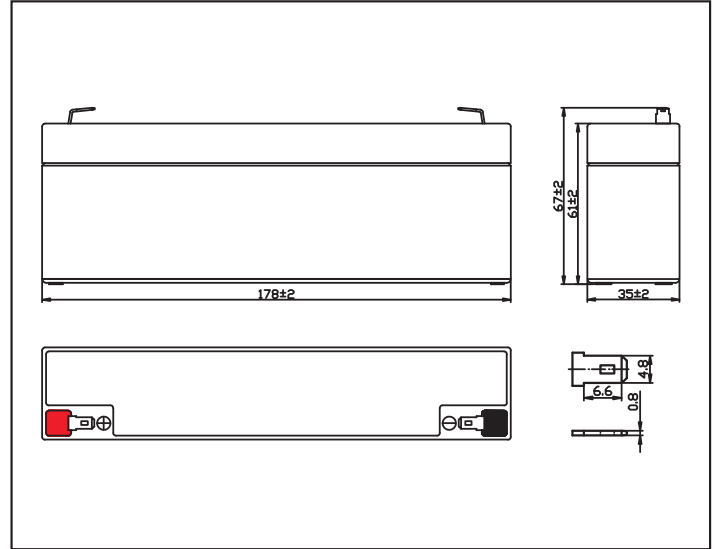

Plane Chart:

Unit:(mm) Terminal type:(F1)



ISO 9001
 ISO 14001
 OHSAS18001



Parameter Chart:

Volts		12V	
Capacity(25°C)	20 hours rate (0.11A)	2.2Ah	
Discharge Current Testing (25°C)	20 I ₂₀ rate (2.2A,27min)	30min	
	60 I ₂₀ rate (6.6A,7min)	7min	
Internal Resistance	Full Charged Battery 25°C	60mΩ	
Capacity Affected By Temperature	40°C	104%	
	25°C	100%	
	0°C	83%	
	-15°C	65%	
Residual Capacity (25°C)	Capacity After 3 Months Storage	91%	
	Capacity After 6 Months Storage	82%	
	Capacity After 12 Months Storage	65%	
Charge (Constant Voltage)	Cycle (25°C)	Initial Charging Current Less Than 0.66A Voltage 14.5~14.9V	
	Float (25°C)	Charge Voltage 13.6~13.8V	
Weight (Approx)		0.91Kg	

Residual Capacity

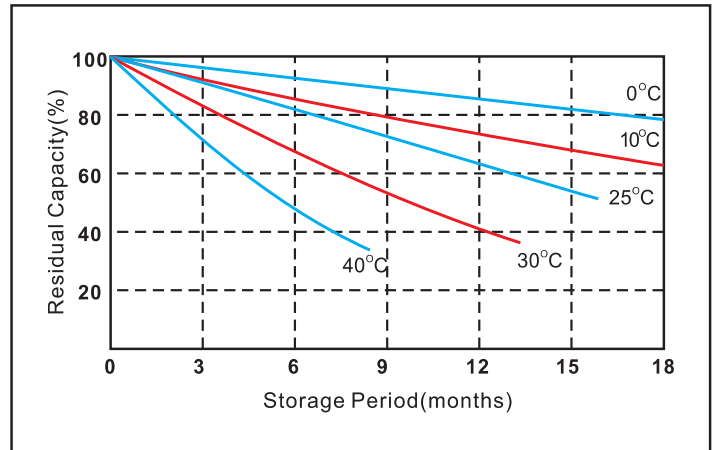

Discharge Current 25°C

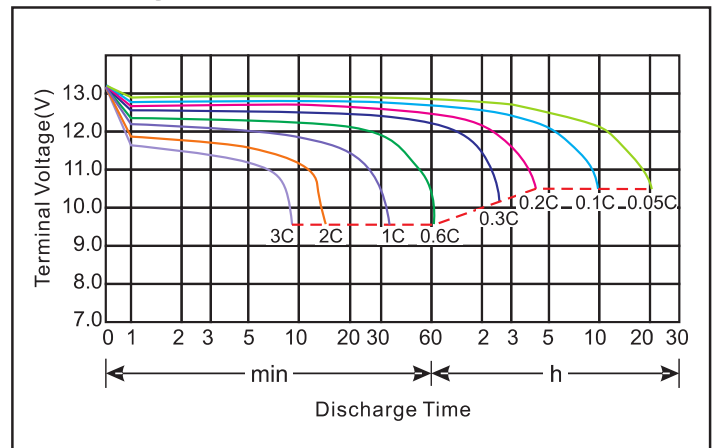

★The above are average and data obtained from the first 3 charge/discharge cycles. These are not minimum values.

MODEL: MC2.3-12

Constant voltage charging characteristics

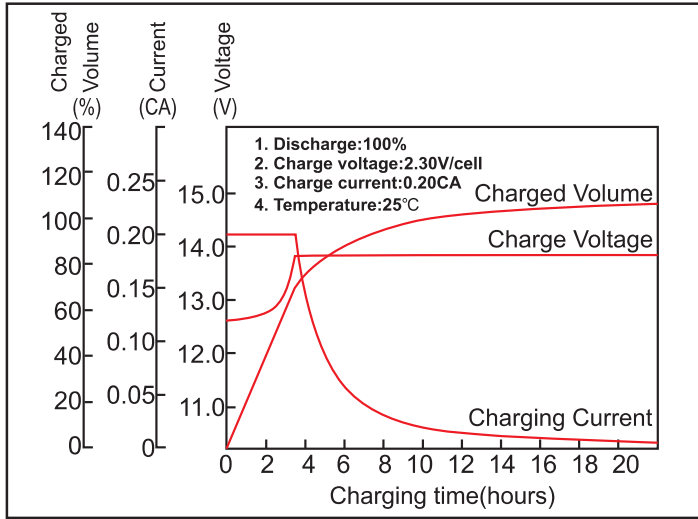

Float Life

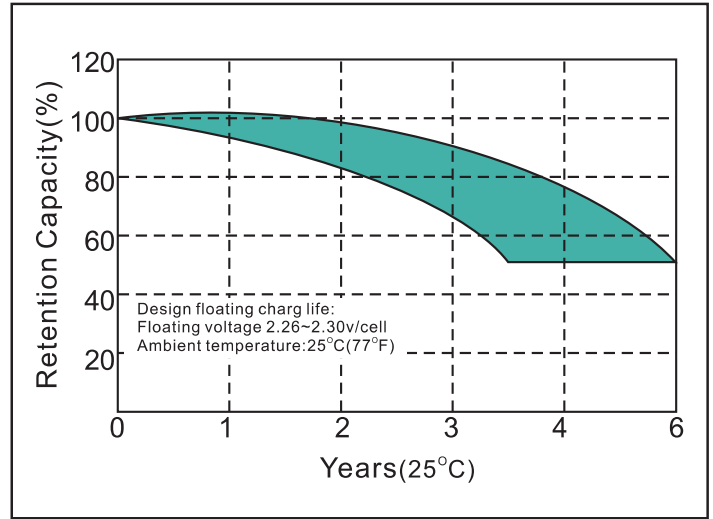

Constant Current Discharge Characteristics (A, 25°C)

F.V/Time	5min	10min	15min	30min	60min	2h	3h	5h	8h	10h	20h
9.60V	7.43	4.74	3.82	2.31	1.29	0.71	0.51	0.35	0.24	0.20	0.12
10.2V	7.07	4.50	3.66	2.22	1.23	0.70	0.50	0.35	0.23	0.19	0.11
10.5V	6.85	4.36	3.57	2.16	1.20	0.70	0.50	0.34	0.23	0.19	0.11
10.8V	6.63	4.22	3.48	2.11	1.17	0.69	0.49	0.34	0.23	0.18	0.10

Constant Current Discharge Characteristics (Watt,25°C)

F.V/Time	5min	10min	15min	30min	60min	2h	3h	5h	8h	10h	20h
9.60V	82.77	53.44	43.39	26.48	14.91	8.34	6.07	4.18	2.82	2.38	1.27
10.2V	78.75	50.63	41.79	25.43	14.30	8.23	5.99	4.14	2.80	2.33	1.26
10.5V	76.34	49.02	40.74	24.79	13.94	8.14	5.91	4.08	2.79	2.28	1.24
10.8V	73.93	47.41	39.70	24.15	13.58	8.05	5.83	4.02	2.77	2.22	1.21

Capacity Factors With Different Temperature

Battery Type		-20°C	-10°C	0°C	5°C	10°C	20°C	25°C	30°C	40°C	45°C
Battery	12V	50%	70%	83%	85%	90%	98%	100%	102%	104%	105%

★The above are average and data obtained from the first 3 charge/discharge cycles. These are not minimum values.